

# ROLL-UP COVERS



P.E.I. Roll-up Covers are normally equipped with our patented system of multiple springs. This offers countless advantages:

- Reliability
- Extremely high speeds
- Resistance to high and low temperatures
- Compact size
- Easy installation
- Constant tensioning
- 1,000,000 movements guaranteed

## ROLL-UP COVERS WITHOUT CANISTER

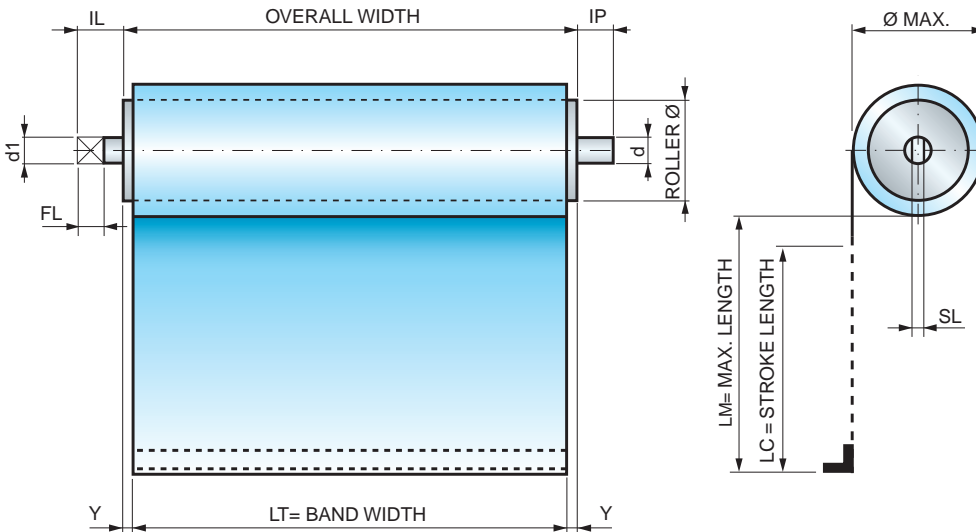

LM		2 · Y =
From	to	
0	400	4
401	600	5
601	800	6
801	1200	8
1201	1600	10
1601	2400	14
2401	3000	18
3001	3850	22
3851	4700	26
4701	5550	32

### Shaft sizes

#### Standard Roll-up Covers

ROLLER Ø	d1	IL	FL	SL	d	IP
30	6	8	8	2,6	7	8
40-50-60-70	10	15	12	4	10	10

For special working conditions, our engineering department can adjust these dimensions. Carefully review the drawing enclosed with the proposal.

#### SURE-SPRING® Roll-up Covers

ROLLER Ø	d1	IL	FL	SL	d	IP
39-52-71	10	15	12	4	10	10

### Formula for calculating the OVERALL WIDTH

$$\text{OVERALL WIDTH} = \text{LT} + 2\text{Y}$$

Example:  
LM = 1000    LT = 500    2Y = 8  
OVERALL WIDTH = 508

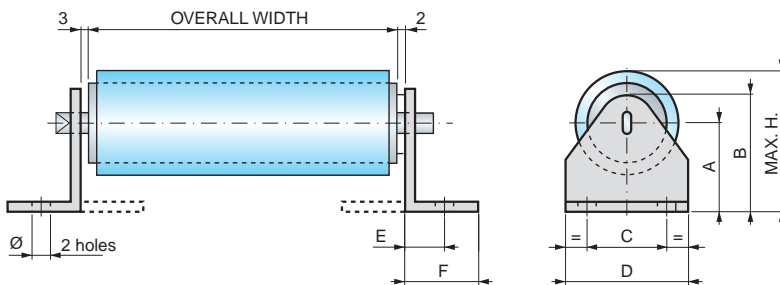

### Measurements for standard supports

Code	A	B	C	D	E	F	Ø	maxH	Material
033	33	45	26	40	11	18	6,5	59	galvanized Fe 15/10
050	50	62	26	40	11	18	6,5	93	galvanized Fe 15/10
060	60	76	36	50	15	22	6,5	112	galvanized Fe 20/10
080	80	96	42	60	17	26	6,5	151	galvanized Fe 25/10
119	119	136	54	106	37	70	10	225	galvanized Fe 40/10

### Formula for calculating max. Ø

$$\text{MAX.Ø} = 2 \cdot \sqrt{\frac{L \cdot s \cdot 1,20}{\pi} + r^2}$$

L = MAX. LENGTH TO WIND  
s = BAND THICKNESS\*  
r = ROLLER Ø/2

(\* see materials list on page 46)

Reproduction of this page is strictly prohibited.

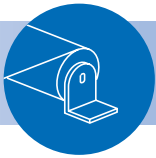

## ROLL-UP COVERS WITH CANISTER

Enclosing the roller offers many advantages:

- Protects roller from accidental impact
- Integral wiper keeps band clean
- Attractive appearance
- Wide variety of fastening systems
- Materials: Aluminum, Steel, Stainless Steel
- 1,000,000 movements guaranteed

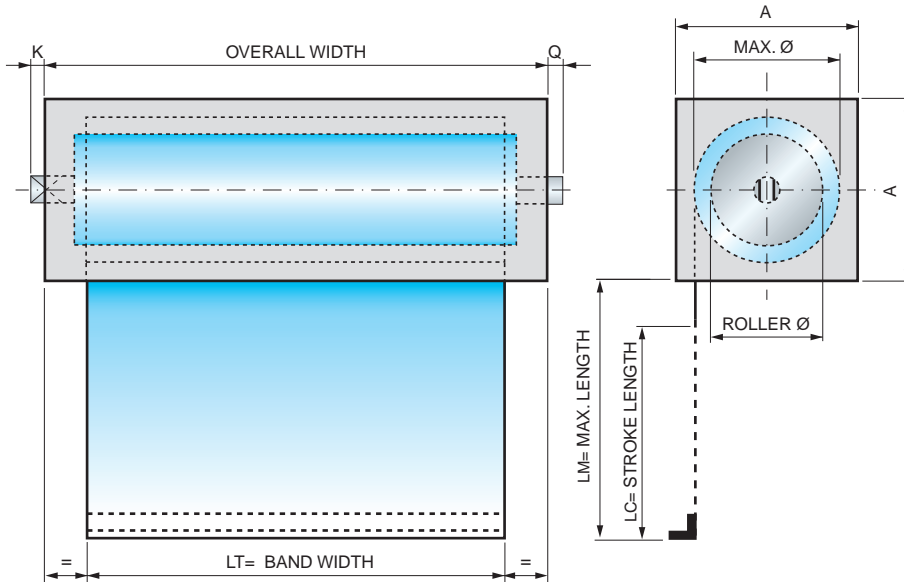

Canisters A x A
40 x 40
50 x 50
60 x 60
70 x 70
80 x 80
90 x 90
100 x 100
110 x 110
120 x 120
130 x 130
140 x 140
150 x 150

Canister material	K	Q	Z*
Aluminum	3	1	25
Steel	10	7	13
Stainless steel	10	7	13

Z\* = FIXED COEFFICIENT

### Recommended sizes

These tables list the recommended MAX. BAND LENGTH based on the OVERALL WIDTH. The values shown are guaranteed at a MAX. SPEED of 40 m/min.

**For higher speeds and for sizes not indicated in the tables, contact our engineering department**

All the Roll-up Covers with or without Canister are manufactured to order.

ROLLER Ø		150	250	350	500	750	1000	1250	1500
ROLLER Ø 30	OVERALL WIDTH	150	250	350	500	750	1000	1250	1500
	MAX. LENGTH	300	500	650	800	1000	1200	1350	1500
ROLLER Ø 40	OVERALL WIDTH	150	250	350	500	750	1000	1250	1500
	MAX. LENGTH	400	600	900	1200	1500	1800	2000	2200
ROLLER Ø 50	OVERALL WIDTH	150	250	350	500	750	1000	1250	1500
	MAX. LENGTH	450	700	1050	1350	1650	2000	2250	2450
ROLLER Ø 60	OVERALL WIDTH	150	250	350	500	750	1000	1250	1500
	MAX. LENGTH	500	1000	1600	1900	2200	2500	2750	3000
ROLLER Ø 70	OVERALL WIDTH	150	250	350	500	750	1000	1250	1500
	MAX. LENGTH	550	1100	1750	2050	2350	2600	2900	3150
ROLLER Ø 80	OVERALL WIDTH	150	250	350	500	750	1000	1250	1500
	MAX. LENGTH	700	1300	2000	2350	2700	3100	3400	3700
ROLLER Ø 90	OVERALL WIDTH	150	250	350	500	750	1000	1250	1500
	MAX. LENGTH	750	1400	2150	2500	2850	3200	3550	3850
ROLLER Ø 100	OVERALL WIDTH	150	250	350	500	750	1000	1250	1500
	MAX. LENGTH	800	1500	2300	2650	3000	3300	3700	4000
ROLLER Ø 120	OVERALL WIDTH	150	250	350	500	750	1000	1250	1500
	MAX. LENGTH	850	1600	2450	2800	3150	3400	3850	4150

### Size examples for SURE-SPRING® Roll-up Covers

ROLLER Ø 39	OVERALL WIDTH	250	350	500	750	1000	1250	1500
	MAX. LENGTH	850	1250	1650	2000	2500	3000	3850
ROLLER Ø 52	OVERALL WIDTH	250	350	500	750	1000	1250	1500
	MAX. LENGTH	1000	1500	2000	2500	3000	3850	4700
ROLLER Ø 71	OVERALL WIDTH	250	350	500	750	1000	1250	1500
	MAX. LENGTH	1400	2100	2400	2850	3700	4800	5550

**Formula for calculating the Minimum canister size = A**

$$A = \text{MAX } \varnothing + 8$$

**Formula for calculating the OVERALL WIDTH**  
With Steel and Stainless Steel canister

$$\text{OVERALL WIDTH} = \text{LT} + \text{Z} + 2\text{Y}^* + \left( \frac{\text{LM}}{100} \right)$$

Example with Steel canister:  
LT= 500      2Y= 8      LM =1000  
LM/100 =10                      Z= 13

OVERALL WIDTH = 531  
(\* see 2Y table on page 9)



## INSTALLING ROLL-UP COVERS

This diagram is valid for all Roll-up Covers, and shows:

- Terminal type
- Terminal position on the band
- Band output direction
- View of shaft/tab

### Horizontal and frontal positions

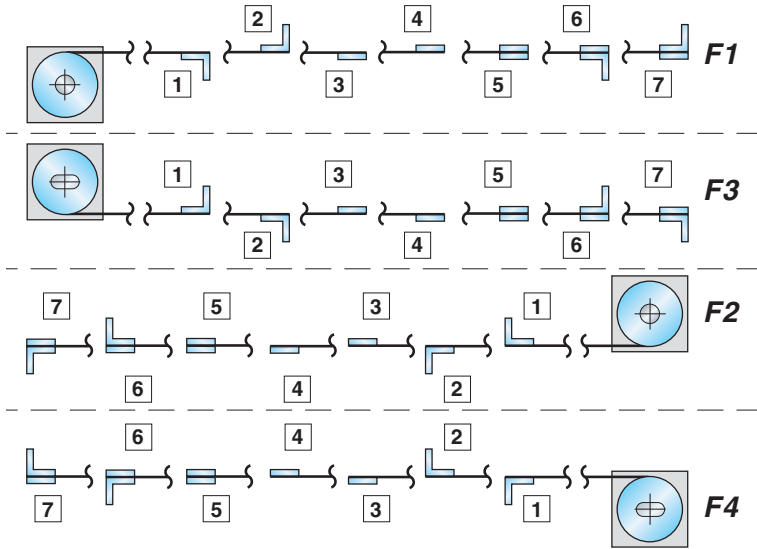

### Vertical positions

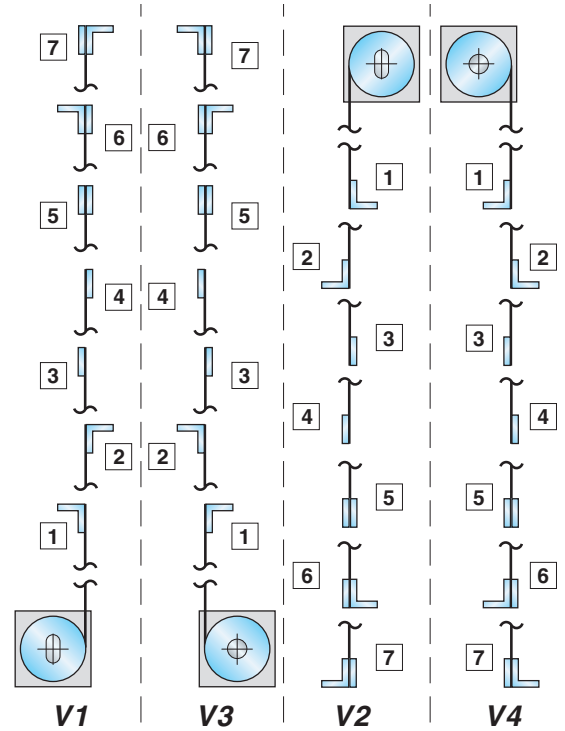

### Terminal materials: Aluminum, Steel

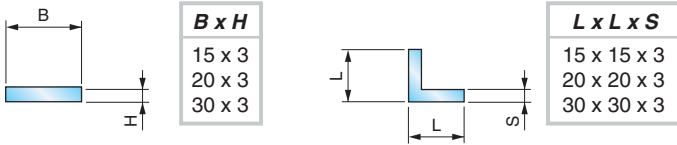

**Standard canister mounting systems:** To describe the canister attachment system, place one of the drawings below over the selected roll-up cover position, above. Do not rotate either drawing.

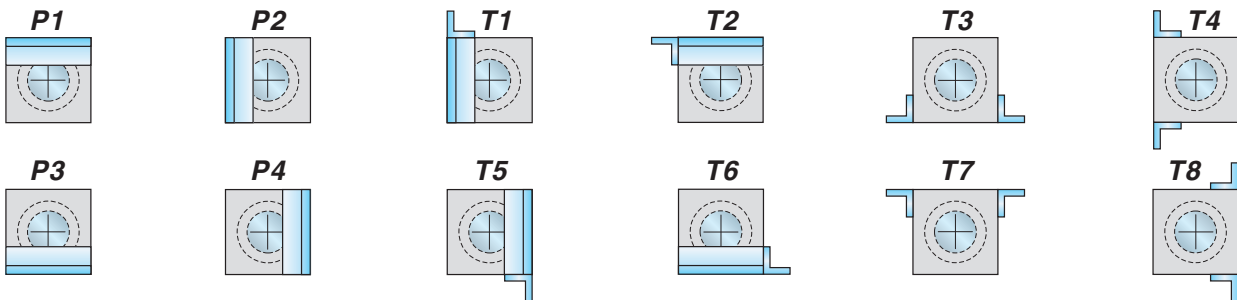

### Positions

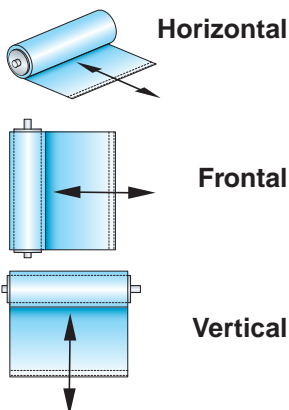

**Wiper:** This diagram shows the 2 ways to install the wiper to the canister.

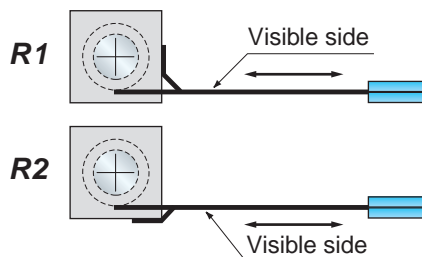

### Example assembling code

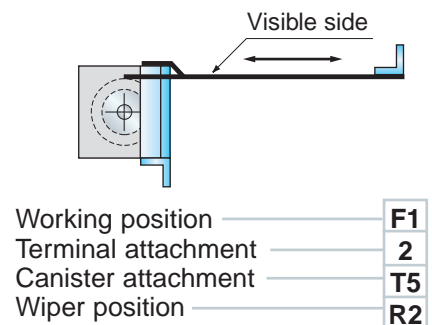

Reproduction of this page is strictly prohibited.

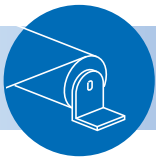

# ROLL-UP COVERS

## ROLL-UP COVERS QUESTIONNAIRE

<p><b>! Type of machine on which the ROLL-UP COVER is to be installed:</b></p> <input type="checkbox"/> METAL working machine <input type="checkbox"/> MARBLE working machine <input type="checkbox"/> GOLD working machine <input type="checkbox"/> PAPER working machine <input type="checkbox"/> FABRIC working machine <input type="checkbox"/> GLASS working machine <input type="checkbox"/> FOOD processing machine <input type="checkbox"/> PHARMACEUTICAL processing machine <input type="checkbox"/> AGRICULTURAL processing machine <input type="checkbox"/> TANNING machinery <input type="checkbox"/> CLAY working machine <input type="checkbox"/> WOOD working machine <input type="checkbox"/> Other .....	<p><b>! Type of material falling on the band:</b></p> <input type="checkbox"/> Steel shavings <input type="checkbox"/> Cast iron shavings <input type="checkbox"/> Brass shavings <input type="checkbox"/> Aluminum shavings <input type="checkbox"/> Wood shavings <input type="checkbox"/> Ambient dust <input type="checkbox"/> Grinding swarf <input type="checkbox"/> Welding splatter <input type="checkbox"/> Other .....	<p><b>! Amount of material falling on the band:</b> ..... Kg</p> <p><b>! Temperature of material falling on the band:</b>.....°C</p> <p><b>! Temperature of work area:</b>.....°C</p> <p><b>! Max. rapid travel speed:</b> .....m/min.</p> <p><b>! Max. acceleration:</b> .....g</p> <p><b>! Max. working motions per hour:</b> .....</p> <p><b>! Max. daily working hours:</b> .....</p>
<p><b>! Liquids to which the band will be exposed:</b></p> <input type="checkbox"/> Water/steam <input type="checkbox"/> Coolant/oils <input type="checkbox"/> Oils with a viscosity of ISO .....		

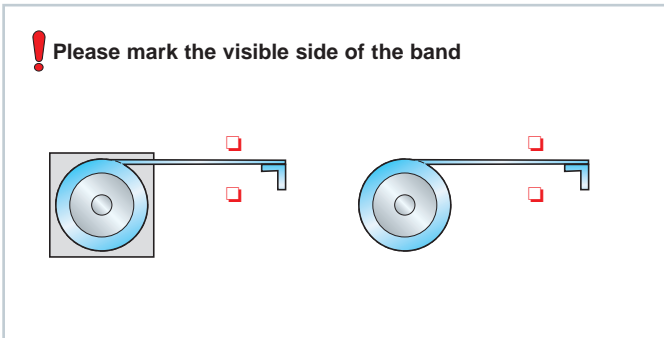

Sketch

**! Company name** .....

**! Contact person:** .....

**! Phone:**..... **! Fax:**.....

**! Quantity:** .....

**! Annual demand:** .....

**! Date:** .....

**! Notes:** .....

.....

<input type="checkbox"/> STANDARD ROLL-UP COVER
<input type="checkbox"/> SURE-SPRING® ROLL-UP COVER
<b>! WITH canister</b> <input type="checkbox"/> <b>! WITHOUT canister</b> <input type="checkbox"/>
<b>! LT= BAND WIDTH</b> ..... mm
<b>! LM= MAX. LENGTH</b> ..... mm
<b>! OVERALL WIDTH</b> calculated..... mm
<b>! Working position:</b> <input type="checkbox"/> Horizontal <input type="checkbox"/> Frontal <input type="checkbox"/> Vertical
<input type="checkbox"/> F 1 <input type="checkbox"/> F 2 <input type="checkbox"/> F 3 <input type="checkbox"/> F 4
<input type="checkbox"/> V 1 <input type="checkbox"/> V 2 <input type="checkbox"/> V 3 <input type="checkbox"/> V 4
<b>• TEMAT Band material code:</b>
<input type="checkbox"/> 001 <input type="checkbox"/> 002 <input type="checkbox"/> 202 <input type="checkbox"/> 003 <input type="checkbox"/> 004 <input type="checkbox"/> 005
<input type="checkbox"/> 007 <input type="checkbox"/> 008 <input type="checkbox"/> 009 <input type="checkbox"/> 091 <input type="checkbox"/> 101 <input type="checkbox"/> 102
<input type="checkbox"/> 104 <input type="checkbox"/> 105 <input type="checkbox"/> 106 <input type="checkbox"/> 011 <input type="checkbox"/> 012 <input type="checkbox"/> 013
<input type="checkbox"/> 014 <input type="checkbox"/> 015 <input type="checkbox"/> 151 <input type="checkbox"/> 161 <input type="checkbox"/> 160 <input type="checkbox"/> 162
<input type="checkbox"/> 164 <input type="checkbox"/> 165 <input type="checkbox"/> 167 <input type="checkbox"/> 169 <input type="checkbox"/> 180 <input type="checkbox"/> 017
<input type="checkbox"/> 018 <input type="checkbox"/> 019 <input type="checkbox"/> 020 <input type="checkbox"/> 022 <input type="checkbox"/> Other.....
<b>• Ø Selected Roller</b> mm
<b>• Ø Calculated Max.</b> ..... mm
<b>• Support code:</b>
<input type="checkbox"/> 033 <input type="checkbox"/> 050 <input type="checkbox"/> 060 <input type="checkbox"/> 080 <input type="checkbox"/> 119
<b>• Canister material:</b> <input type="checkbox"/> Alu <input type="checkbox"/> Steel <input type="checkbox"/> Stainless steel
<b>• Canister dimensions:</b>
<input type="checkbox"/> 40x40 <input type="checkbox"/> 50x50 <input type="checkbox"/> 60x60 <input type="checkbox"/> 70x70
<input type="checkbox"/> 80x80 <input type="checkbox"/> 90x90 <input type="checkbox"/> 100x100 <input type="checkbox"/> 110x110
<input type="checkbox"/> 120x120 <input type="checkbox"/> 130x130 <input type="checkbox"/> 140x140 <input type="checkbox"/> 150x150
<b>• Canister attachment system:</b>
<input type="checkbox"/> P1 <input type="checkbox"/> P2 <input type="checkbox"/> P3 <input type="checkbox"/> P4 <input type="checkbox"/> T1 <input type="checkbox"/> T2
<input type="checkbox"/> T3 <input type="checkbox"/> T4 <input type="checkbox"/> T5 <input type="checkbox"/> T6 <input type="checkbox"/> T7 <input type="checkbox"/> T8
<b>• Wiper position:</b> <input type="checkbox"/> R 1 <input type="checkbox"/> R 2
<b>• Terminal attachment system:</b>
<input type="checkbox"/> 1 <input type="checkbox"/> 2 <input type="checkbox"/> 3 <input type="checkbox"/> 4 <input type="checkbox"/> 5 <input type="checkbox"/> 6 <input type="checkbox"/> 7
<b>• Terminal material:</b> <input type="checkbox"/> Aluminum <input type="checkbox"/> Steel
<input type="checkbox"/> 15x3 <input type="checkbox"/> 20x3 <input type="checkbox"/> 30x3
<input type="checkbox"/> 15x15x3 <input type="checkbox"/> 20x20x3 <input type="checkbox"/> 30x30x3

GENERAL TOLERANCES ± 1%

NOTE: The data fields and/or tables marked by **!** are required in order to give you a quotation.

Reproduction of this page is strictly prohibited.